



**NATIONAL  
GEOGRAPHIC™**

**BRESSER**

**TELESKOPE  
MIT AZ MONTIERUNG  
TELESCOPES  
WITH AZ MOUNT**

**TÉLESCOPES  
ÉQUIPÉS D'UNE  
MONTURE AZ  
TELESCOPIOS  
CON MONTURA AZ**

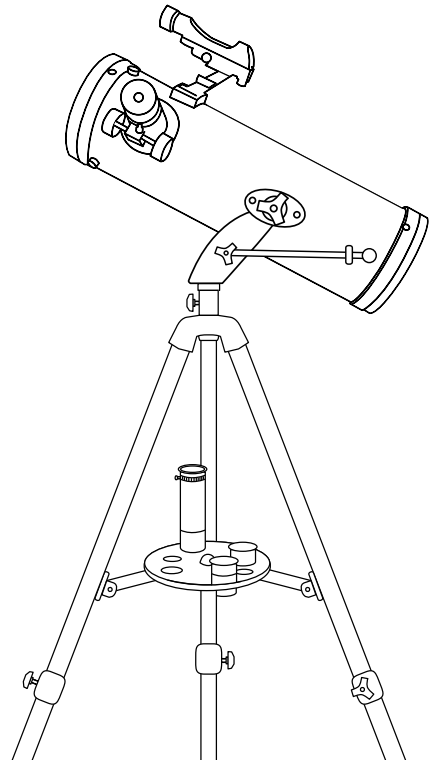
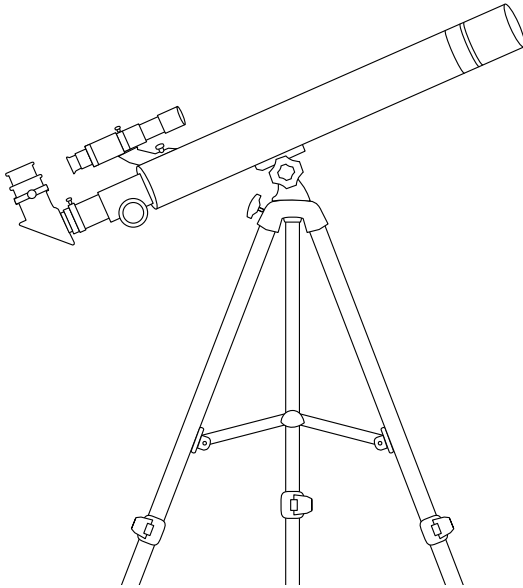

- DE** Bedienungsanleitung
- EN** Operating instructions
- FR** Mode d'emploi
- ES** Instrucciones de uso

AZ MOUNT



**(DE) WARNUNG:** Schauen Sie mit diesem Gerät niemals direkt in die Sonne oder in die Nähe der Sonne. Es besteht **ERBLINDUNGSGEFAHR!**

**(EN) WARNING:** Never use this device to look directly at the sun or in the direct proximity of the sun. Doing so may result in a risk of blindness.

**(FR) AVERTISSEMENT!** Ne regardez jamais avec cet appareil directement ou à proximité du soleil ! Veuillez y particulièrement, lorsque l'appareil est utilisé par des enfants ! Il existe un **DANGER DE PERTE DE LA VUE !**

**(ES) ADVERTENCIA!** No utilice nunca este aparato óptico para mirar directamente al sol a las inmediaciones de éste. Tome asimismo precauciones especiales si va a ser utilizado por niños, pues existe el **PELIGRO DE QUE SE QUEDEN CIEGOS.**

### **(DE) Allgemeine Warnhinweise**

- **ERBLINDUNGSGEFAHR!** Schauen Sie mit diesem Gerät niemals direkt in die Sonne oder in die Nähe der Sonne. Es besteht **ERBLINDUNGSGEFAHR!**
- **ERSTICKUNGSGEFAHR!** Kinder sollten das Gerät nur unter Aufsicht benutzen. Verpackungsmaterialien (Plastiktüten, Gummibänder, etc.) von Kindern fernhalten! Es besteht **ERSTICKUNGSGEFAHR!**
- **BRANDGEFAHR!** Setzen Sie das Gerät – speziell die Linsen – keiner direkten Sonneneinstrahlung aus! Durch die Lichtbündelung könnten Brände verursacht werden.
- Bauen Sie das Gerät nicht auseinander! Wenden Sie sich im Falle eines Defekts an Ihren Fachhändler. Er nimmt mit dem Service-Center Kontakt auf und kann das Gerät ggf. zwecks Reparatur einschicken.
- Setzen Sie das Gerät keinen hohen Temperaturen aus.
- Das Gerät ist für den Privatgebrauch gedacht. Achten Sie die Privatsphäre Ihrer Mitmenschen – schauen Sie mit diesem Gerät zum Beispiel nicht in Wohnungen!

### **(EN) General Warnings**

- **Risk of blindness** – Never use this device to look directly at the sun or in the direct proximity of the sun. Doing so may result in a risk of blindness.
- **Choking hazard** – Children should only use the device under adult supervision. Keep packaging material, like plastic bags and rubber bands, out of the reach of children, as these materials pose a choking hazard.
- **Risk of fire** – Do not place the device, particularly the lenses, in direct sunlight. The concentration of light could cause a fire.
- Do not disassemble the device. In the event of a defect, please contact your dealer. The dealer will contact the Service Centre and can send the device in to be repaired, if necessary.
- Do not expose the device to high temperatures.
- The device is intended only for private use. Please heed the privacy of other people. Do not use this device to look into apartments, for example.

## (FR) Consignes générales de sécurité

- **RISQUE DE CECITE !** Ne jamais regarder directement le soleil à travers cet appareil en le pointant directement en sa direction. L'observateur court un RISQUE DE CECITE !
- **RISQUE D'ETOUFFEMENT !** Les enfants ne doivent utiliser cet appareil que sous surveillance. Maintenez les enfants éloignés des matériaux d'emballage (sacs plastiques, bandes en caoutchouc, etc.) ! RISQUE D'ETOUFFEMENT !
- **RISQUE D'INCENDIE !** Ne jamais orienter l'appareil – en particuliers les lentilles – de manière à capter directement les rayons du soleil ! La focalisation de la lumière peut déclencher des incendies.
- Ne pas démonter l'appareil ! En cas de défaut, veuillez vous adresser à votre revendeur spécialisé. Celui-ci prendra contact avec le service client pour, éventuellement, envoyer l'appareil en réparation.
- Ne pas exposer l'appareil à des températures trop élevées.
- Les unités sont destinées à un usage privé. Respectez la sphère privée de vos concitoyens et n'utilisez pas ces unités pour, par exemple, observer ce qui se passe dans un appartement !

## (ES) Advertencias de carácter general

- **¡Existe PELIGRO DE CEGUERA!** No mire nunca directamente al sol o cerca de él con este aparato. ¡Existe PELIGRO DE CEGUERA!
- **¡Existe PELIGRO DE ASFIXIA!** Los niños solo deberían utilizar el aparato bajo supervisión. Mantener los materiales de embalaje (bolsas de plástico, bandas de goma) alejadas del alcance de los niños. ¡Existe PELIGRO DE ASFIXIA!
- **¡PELIGRO DE INCENDIO!** No exponer el aparato – especialmente las lentes – a la radiación directa del sol. La concentración de la luz puede provocar incendios.
- No desmonte el aparato. En caso de que exista algún defecto, le rogamos que se ponga en contacto con su distribuidor autorizado. Este se pondrá en contacto con el centro de servicio técnico y, dado el caso, podrá enviarle el aparato para su reparación.
- No exponga el aparato a altas temperaturas.
- La aparato están concebidos para el uso privado. Respete la privacidad de las personas de su entorno – por ejemplo, no utilice este aparato para mirar en el interior de viviendas.

## MANUAL DOWNLOAD:

**DE** Besuchen Sie unsere Website über den folgenden QR Code oder Weblink um weitere Informationen zu diesem Produkt oder die verfügbaren Übersetzungen dieser Anleitung zu finden.

**EN** Visit our website via the following QR Code or web link to find further information on this product or the available translations of these instructions.

**FR** Si vous souhaitez obtenir plus d'informations concernant ce produit ou rechercher ce mode d'emploi en d'autres langues, rendez-vous sur notre site Internet en utilisant le code QR ou le lien correspondant.

**NL** Bezoek onze internetpagina via de volgende QR-code of weblink, voor meer informatie over dit product of de beschikbare vertalingen van deze gebruiksaanwijzing.

**IT** Desidera ricevere informazioni esaustive su questo prodotto in una lingua specifica? Venga a visitare il nostro sito Web al seguente link (codice QR Code) per conoscere le versioni disponibili.

**ES** ¿Desearía recibir unas instrucciones de uso completas sobre este producto en un idioma determinado? Entonces visite nuestra página web utilizando el siguiente enlace (código QR) para ver las versiones disponibles.

**PT** Deseja um manual detalhado deste produto numa determinada língua? Visite a nossa Website através da seguinte ligação (QR Code) das versões disponíveis.

**DK** Ønsker du en udførlig vejledning til dette produkt på et bestemt sprog? Så besøg vores website ved hjælp af følgende link (QR-kode) for tilgængelige versioner.

**PL** Prosimy więc odwiedzić naszą stronę, korzystając z tego linku (QR Code), aby zapoznać się dostępnymi wersjami.

**CZ** Přejete si podrobný návod k produktu v určitém jazyce? Pak navštivte naši webovou stránku přes následující odkaz (QR Code) a zjistěte, zdali máme Vámi požadovanou verzi k dispozici.

**SE** Önskar du en utförlig anvisning för den här produkten på ett visst språk? Besök i så fall vår webbsajt via följande länk (QR-kod) för tillgängliga versioner.

**FI** Haluatko tuotteen täydellisen ohjeen tietyllä kielellä? Käy silloin sivustossamme, jossa ovat saatavilla olevat versiot. Käytä seuraavaa linkkiä (QR Code).

**SK** Chceš podrobné pokyny pre tento produkt v konkrétnom jazyku? Potom navštívte naše webové stránky prostredníctvom odkazu uvedeného nižšie (QR kód) dostupné verzie.

**RU** Вам требуется подробная инструкция на это изделие на определенном языке? Проверьте наличие соответствующей версии инструкции, посетив наш сайт по этой ссылке (QR-код).



## MANUAL DOWNLOAD:



[www.bresser.de/download/NGKids/Telescopes](http://www.bresser.de/download/NGKids/Telescopes)



## SERVICE AND WARRANTY:



[www.bresser.de/warranty\\_terms](http://www.bresser.de/warranty_terms)

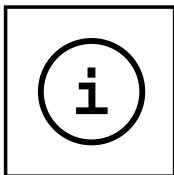

## TELESCOPE GUIDE:



[www.bresser.de/guide](http://www.bresser.de/guide)



## TELESCOPE FAQ:



[www.bresser.de/faq](http://www.bresser.de/faq)

<b>DE</b>	<b>Bedienungsanleitung .....</b>	<b>6</b>
<b>EN</b>	<b>Operating instructions .....</b>	<b>20</b>
<b>FR</b>	<b>Mode d'emploi.....</b>	<b>34</b>
<b>ES</b>	<b>Instrucciones de uso .....</b>	<b>48</b>

Prüfe zuerst ob dein Teleskop vergleichbar mit Beispiel A oder Beispiel B ist.  
Dein Teleskop kann auch Eigenschaften aus beiden Beispielen enthalten.

**Beispiel A: Linsenteleskop mit Sucherfernrohr**

**A**

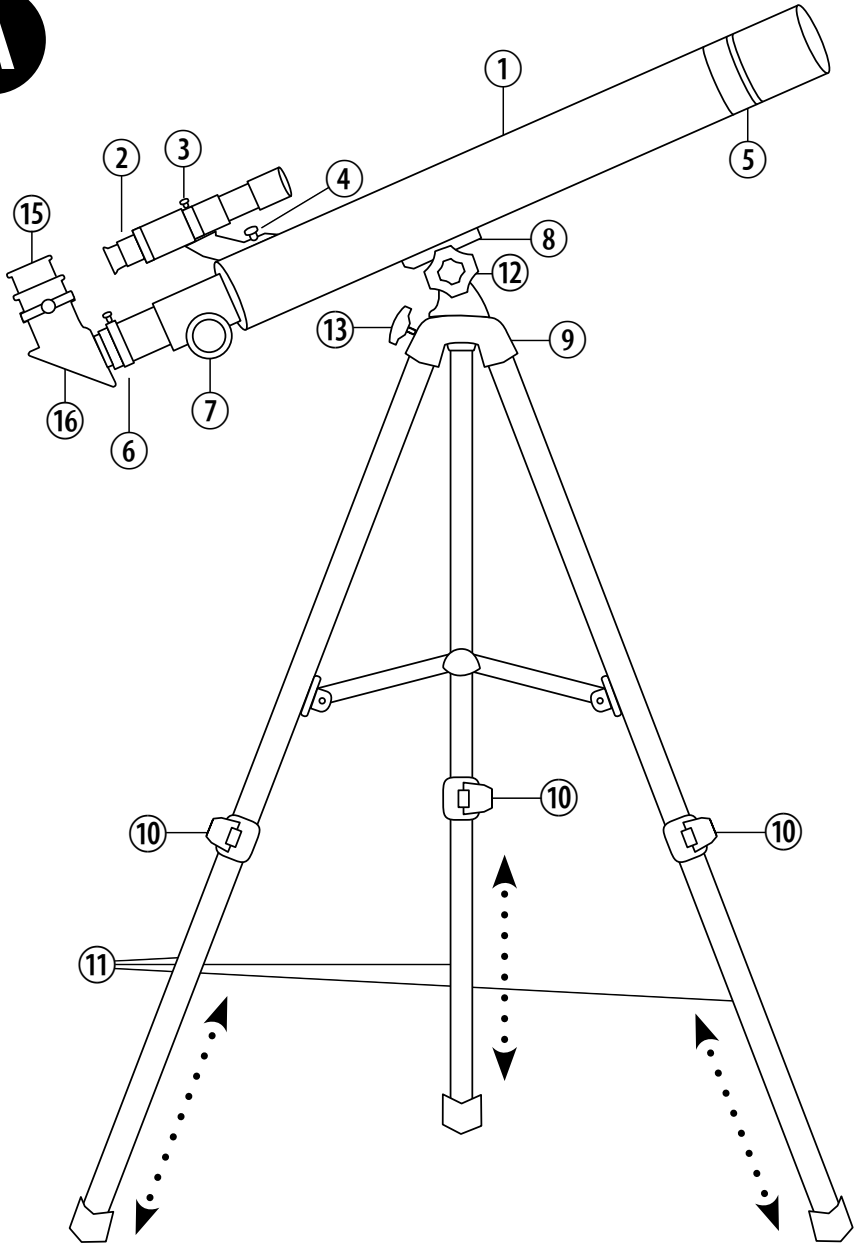

Accessories may vary depending on the model

Parts overview

- 1. Telescope (refractor telescope tube)
- 2. Viewfinder
- 3. Adjusting screws for the viewfinder
- 4. Attaching screws and nuts for the holder of the viewfinder
- 5. Objective lens
- 6. Eyepiece holder (eyepiece connector)
- 7. Focus wheel
- 8. Telescope connecting piece
- 9. Tripod head with holder
- 10. Locking clips or screw for the tripod legs
- 11. Tripod legs (extendable)
- 12. Locking screw for the vertical fine adjustment (upward and downward motion)
- 13. Locking screw for the vertical axis (for turning to the right and left)
- 14. Accessory tray (Example B)
- 15. Eyepiece(s)
- 16. Zenith mirror
- 17. Moon filter
- 18. Erecting lens  
(Optionally possible: Barlow lens)

Viewfinder:

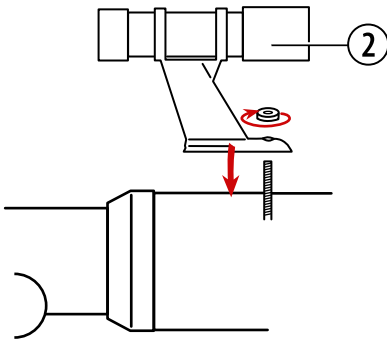

Zenith mirror:

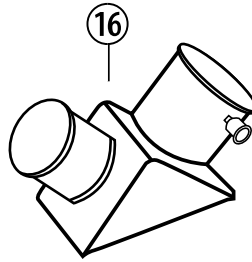

Erecting lens:

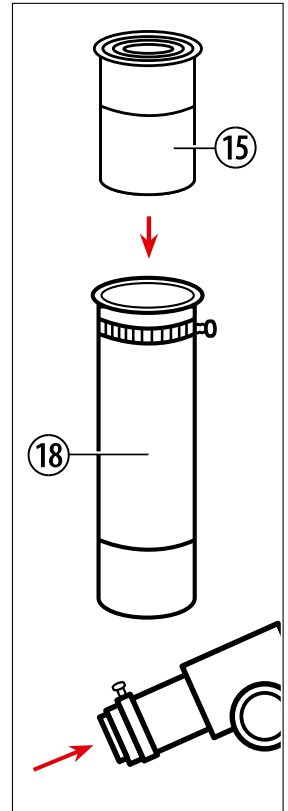

Eyepieces:

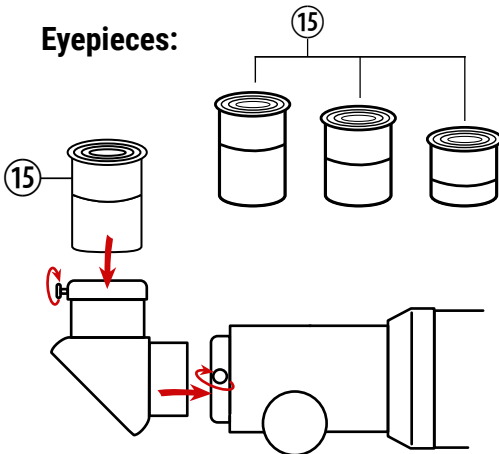

Moon filter:

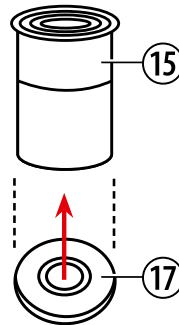

First check if your telescope is comparable to example A or example B.  
Your telescope may also contain features from both examples.

**Example B: Reflector telescope with LED viewfinder and vertical fine adjustment**

**B**

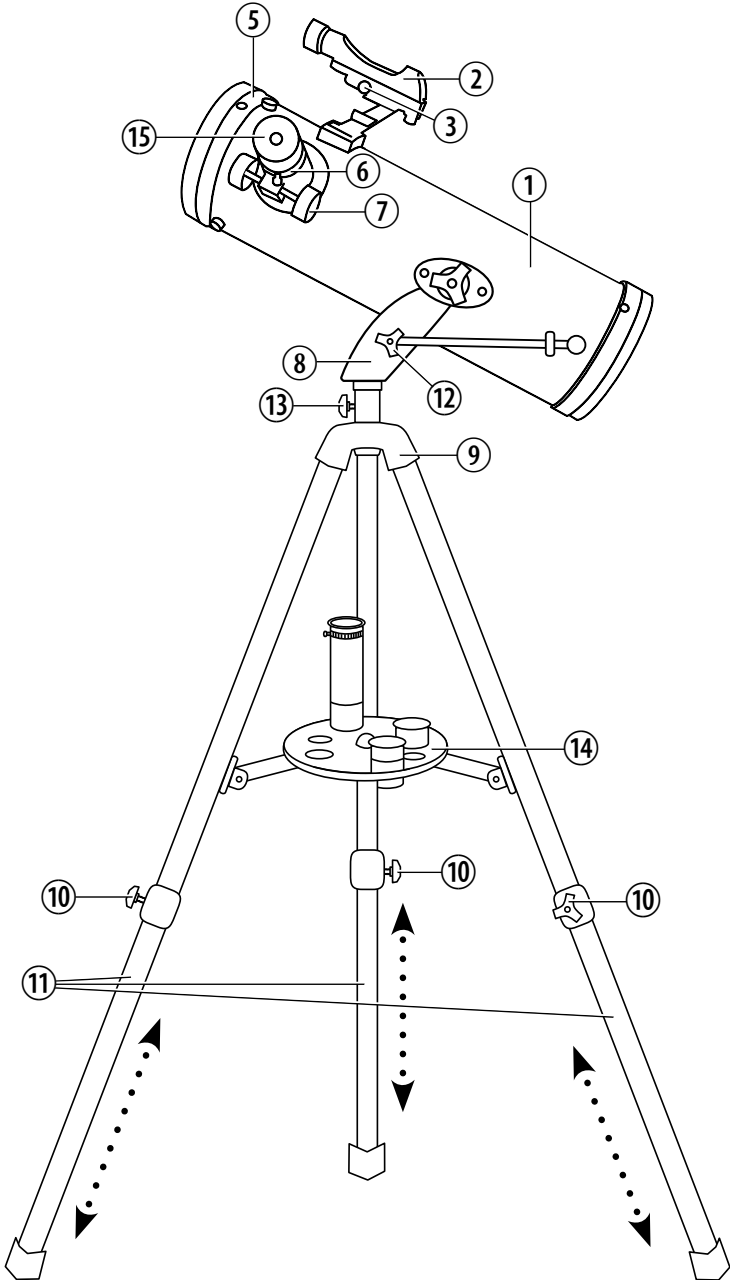

**Accessories may vary depending on the model**

**Parts overview**

- 1. Telescope (reflector telescope tube)
- 2. LED viewfinder
- 3. Adjusting screws
- 4. Attaching screws (Example A)
- 5. Mirror opening
- 6. Eyepiece holder (eyepiece connector)
- 7. Focus wheel
- 8. Telescope connecting piece
- 9. Tripod head with holder
- 10. Locking clips or screw for the tripod legs
- 11. Tripod legs (extendable)
- 12. Locking screw for the vertical fine adjustment (upward and downward motion)
- 13. Locking screw for the vertical axis (for turning to the right and left)
- 14. Accessory tray
- 15. Eyepiece(s)
- 16. Zenith mirror (Example A)
- 17. Moon filter
- 18. Erecting lens  
(Optionally possible: Barlow lens)

**LED viewfinder:**

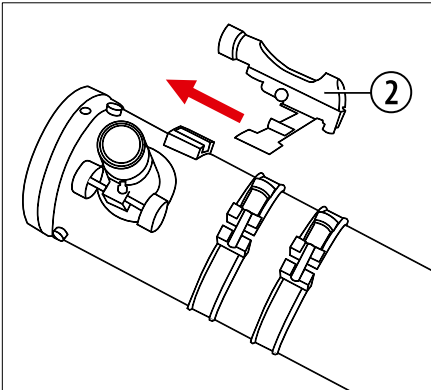

**Moon filter:**

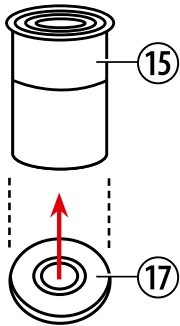

**Erecting lens:**

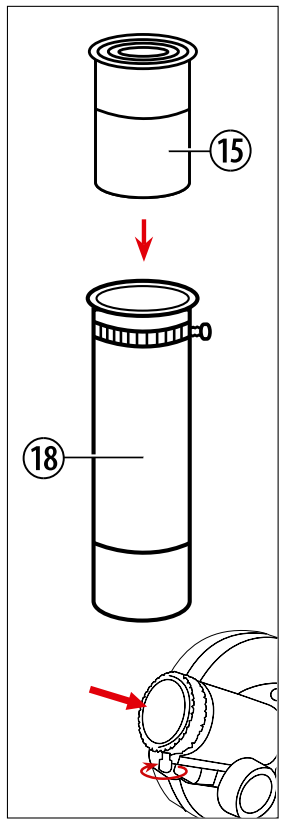

**Eyepiece(s):**

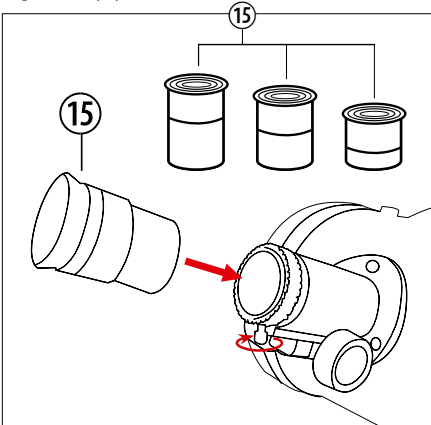

## How to assemble the telescope

Before you get started with the assembly, you should take some time to decide where you would like to set up your telescope. It is important that you choose a place from which you have an uninhibited view of the sky, where the floor is hard and even, and where you have enough space around you so that you feel comfortable. When you've found the ideal spot, you can begin the assembly.

### Example A

Shown is a refractor telescope with viewfinder on an AZ mount.

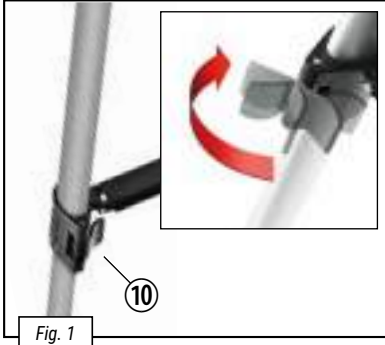

Open the locking clips on the tripod legs (10). Then pull the lower parts of the tripod legs (11) downward as far as they will go. Finally, close the locking clips again (Fig. 1). You can change the height of the tripod at a later time by making the tripod legs a bit shorter (again, opening the locking clips, adjusting the legs, closing the clips).

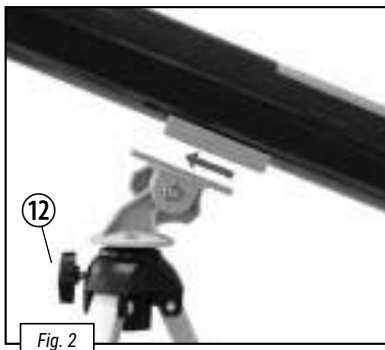
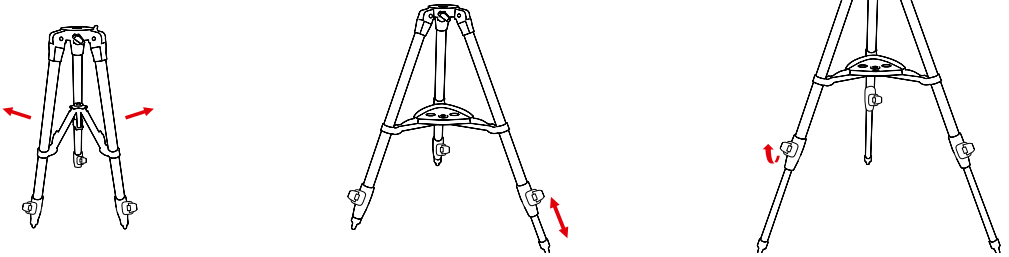

Connect the telescope (1) to the tripod by pushing the telescope connecting piece (8) into the holder on the tripod head (9) (Fig. 2). Screw the locating screw for the vertical fine adjustment (12) into the holder in order to firmly connect both parts.

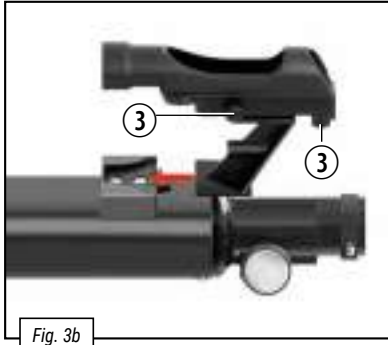
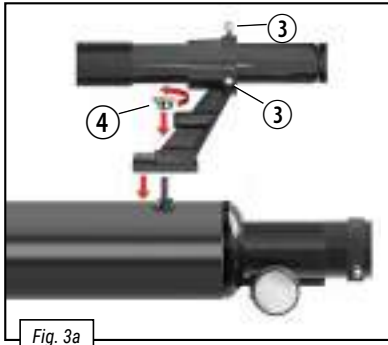

### Viewfinder / LED viewfinder

Depending on the telescope model you have, screw your viewfinder or LED viewfinder to the holder (Fig. 3a) or insert it directly (Fig. 3b). Then affix the viewfinder with screws. Check carefully which step is right for your viewfinder.

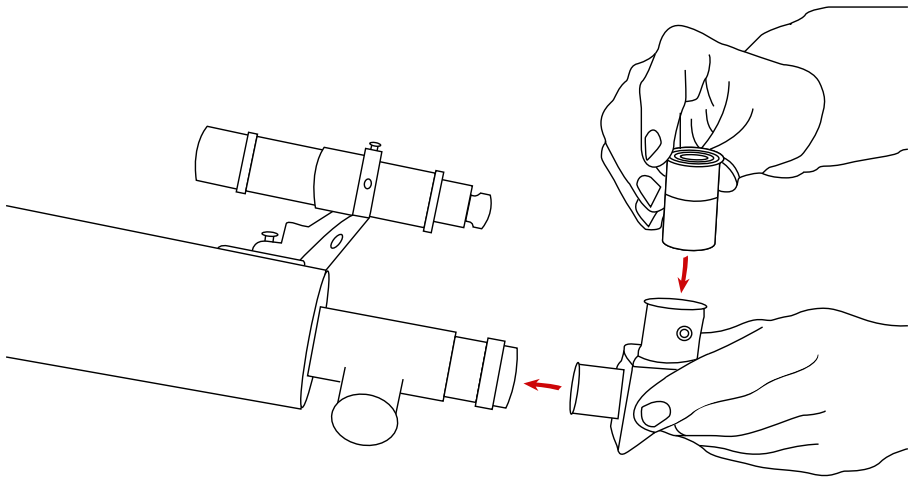

### How to insert an eyepiece if you use a refractor telescope:

Take the lens cap off the eyepiece (6). You can now place the zenith mirror (16) into the eyepiece holder and secure it with the small screw on the connector (Fig. 4). Next, set the eyepiece (15) into the opening of the zenith mirror (16) (Fig. 4). Here too, there is a screw with which you can screw the eyepiece onto the zenith mirror.

**Note:** First, put the eyepiece with the largest focal width (e.g. 20 mm) onto the zenith mirror. While you'll get the least amount of magnification, it will be easier for you to view things.

## Example B

A reflecting telescope with LED viewfinder and vertical fine adjustment on an AZ mount is shown.

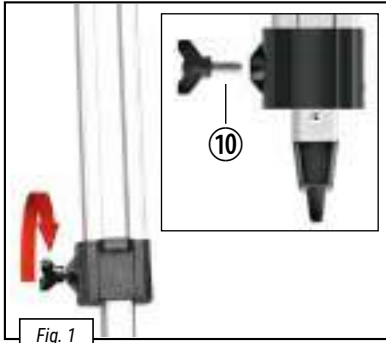

Fix the tripod to the tripod head with the help of the wing screw, washers and wing nuts (Fig. 1).

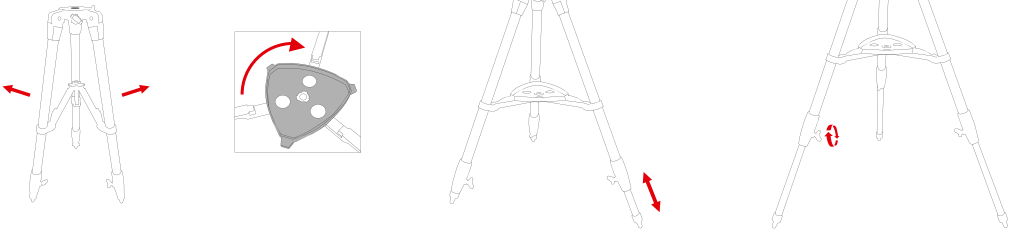

## Attaching the accessory tray

Depending on which tripod is included, the accessory tray must be fitted accordingly. Fig. 2a shows an accessory tray which is fixed with screws. Fig. 2b shows an accessory tray which is mounted by turning clockwise.

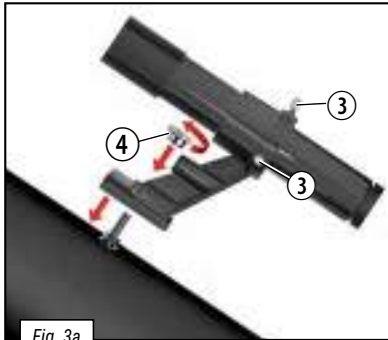

Fig. 3a



Fig. 3b

### Viewfinder / LED viewfinder

Depending on the telescope model you have, screw your viewfinder or LED viewfinder to the holder (Fig. 3a) or insert it directly (Fig. 3b). Then affix the viewfinder with screws. Check carefully which step is right for your viewfinder.

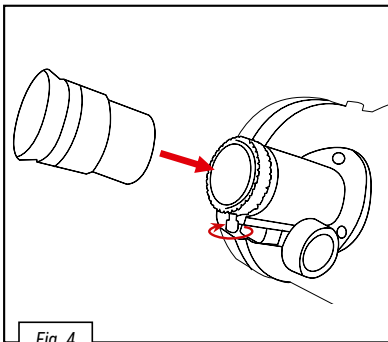

Fig. 4

### How to insert an eyepiece if you use a reflecting telescope:

Take the lens cap off the eyepiece (6). You can now place the eyepiece (15) into the eyepiece holder and secure it with the small screw on the connector (Fig. 4).

**Note:** First, put the eyepiece with the largest focal width (e.g. 20 mm) onto the zenith mirror. While you'll get the least amount of magnification, it will be easier for you to view things.

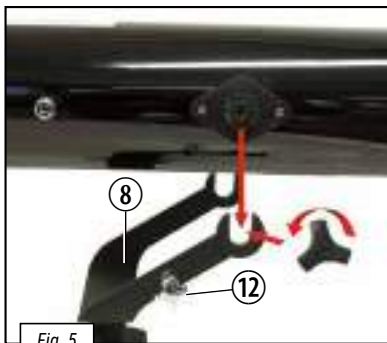

Fig. 5



Fig. 6

Next, screw the vertical fine adjustment to the protruding silver metal supports on the telescope tube. It is best if you let someone help you. Then you need to attach the telescope tube to the tripod. To do so, use the spiral screw to screw the tube to the tripod head (Fig. 5). Attach the locking screw for the vertical fine adjustment to the tripod head yoke (Fig. 6).

## Which eyepiece is right?

It is important that you always choose an eyepiece (15) with the highest focal width for the beginning of your observation. Afterwards, you can gradually move to eyepieces with smaller focal widths. The focal width is indicated in millimeters and is written on each eyepiece. In general, the following is true: The larger the focal width of an eyepiece, the smaller the magnification. There is a simple formula for calculating the magnification:

**Formula for calculating magnification:**

$$\text{Focal length (Telescope)} \div \text{Focal length (Eyepiece)} = \text{Magnification}$$

**Examples:**

600 mm	÷	20 mm	=	30X
600 mm	÷	12.5 mm	=	48X
600 mm	÷	4 mm	=	150X

## Azimuthal mounting

Azimuthal mounting just means that you can move your telescope up and down, left and right, without having to adjust the tripod. With the help of the azimuth safety and the screws for the vertical fine adjustment, you can lock your telescope in order to fix on an object (have this object right in your field of vision). With the help of the vertical fine adjustment, you can move the telescope slowly up and down. And after you release the azimuth safety, you can move it right and left.

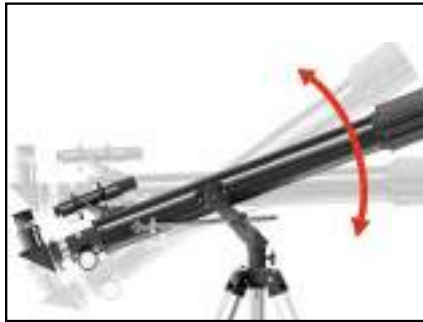

## Before looking through your telescope for the first time

Before you look at something for the first time, you must coordinate the viewfinder and the telescope lens. You have to position the viewfinder in such a way that you see the same thing through it as you do through the eyepiece of the telescope. This is the only way you can use your viewfinder to hone in roughly on objects before you observe these objects magnified through the telescope eyepiece.

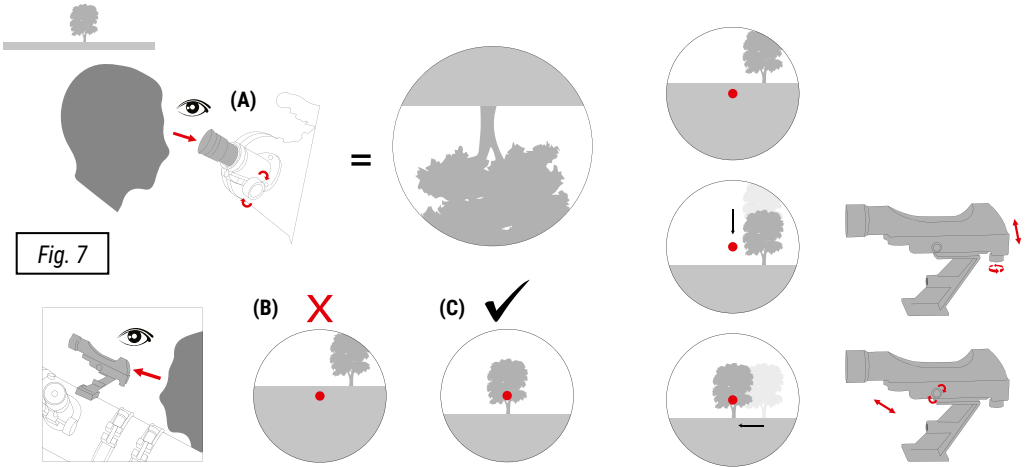

## Coordinating the viewfinder and the telescope

Look through the telescope eyepiece (15) and hone in on a far away object that you can see well (for instance, a tree). Focus in on the object with the focus knob in the way shown in Fig. 7a.

**Note:** The object must be located in the middle of your field of vision when you look through the telescope eyepiece.

**Tip:** If you loosen the locating screws for the vertical fine adjustment (12) and the vertical axis (13), you will be able to move the telescope (1) to the right and left, up and down. When you have the object well placed in your field of vision, you can retighten the locating screws and fix the position of the telescope. Next, look through the viewfinder (2). You will see the image of the object you honed in on in the crosshairs. The image will be upside down.

**Note:** The image you see through the viewfinder is upside down because the lenses are inverting it. This is completely normal, and not an error.

If the image you're looking at through the viewfinder is not exactly in the middle of the crosshair (Fig. 7b), then you must turn the adjusting screws for the viewfinder (3). Turn the screws until the image is positioned in the middle of the crosshair (Fig. 7c). When you look through the eyepiece (14), you should now see the same image detail as you see when you look through the viewfinder (but upside down of course).

**Important:** The viewfinder and telescope are properly matched only when both image sections are equal.

## Use of the moon filter

If the image of the moon is too bright for you, you can screw the green moon filter (17) into the bottom of the thread of the eyepiece (15). Then you can set the eyepiece normally into the zenith mirror (16). The image that you see by looking through the eyepiece is now greenish. The moon appears less bright, so observation is more pleasant.

## Notes on cleaning

- Clean the eyepieces and lenses only with a soft, lint-free cloth, like a microfibre cloth. To avoid scratching the lenses, use only gentle pressure with the cleaning cloth.
- To remove more stubborn dirt, moisten the cleaning cloth with an eyeglass-cleaning solution, and wipe the lenses gently.
- Protect the device from dust and moisture. After use, particularly in high humidity, let the device acclimatize for a short period of time, so that the residual moisture can dissipate before storing.

## Possible observation targets

The following section details several interesting and easy-to-find celestial objects you may want to observe through your telescope. The pictures show what the objects will look like through your telescope's eyepiece.

### Moon



**f=20 mm**



**f=6 mm**

The moon is Earth's only natural satellite.

Diameter: 3,476 km / Distance: 384,400 km from Earth (average)

The moon has been known to humans since prehistoric times. It is the second brightest object in the sky, after the sun. Because the moon circles the Earth once per month, the angle between the Earth, the moon and the sun is constantly changing; one sees this change in the phases of the moon. The time between two consecutive new moon phases is about 29.5 days (709 hours).

### Constellation Orion:

#### The Orion Nebula (M 42)



**f=20 mm**

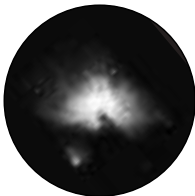

**f=6 mm**

Right Ascension: 05<sup>h</sup> 35<sup>m</sup> (hours : minutes) / Declination: -05° 22' (Degrees : minutes) Distance: 1,344 light years from Earth

Though it is more than 1,344 light years from Earth, the Orion Nebula (M 42) is the brightest diffuse nebula in the sky. It is visible even with the naked eye and a worthwhile object for telescopes of all types and sizes. The nebula consists of a gigantic cloud of hydrogen gas with a diameter of hundreds of light years.

## Constellation Lyra: The Ring Nebula (M 57)



f=20 mm



f=6 mm

Right Ascension: 18h 53m (hours : minutes) /  
Declination: +33° 02' (Degrees : minutes)  
Distance: 2,412 light years from Earth

The famous Ring Nebula (M57) in the Lyra constellation is often viewed as the prototype of a planetary nebula. It is one of the magnificent features of the Northern Hemisphere's summer sky. Recent studies have shown that it is probably comprised of a ring (torus) of brightly shining material that surrounds the

central star (only visible with larger telescopes), and not a gas structure in the form of a sphere or an ellipse. If you were to look at the Ring Nebula from the side, it would look like the Dumbbell Nebula (M 27). When viewed from Earth, we are looking directly at the pole of the nebula.

## Constellation Vulpecula (Little Fox): The Dumbbell Nebula (M 27)

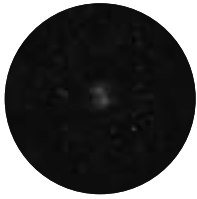

f=20 mm

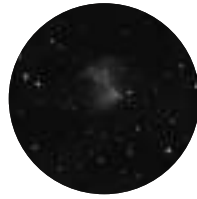

f=6 mm

Right Ascension: 19h 59m (hours : minutes) /  
Declination: +22° 43' (Degrees : minutes)  
Distance: 1,360 light years from Earth

The Dumbbell Nebula (M 27) was the first planetary nebula ever discovered. On 12 July 1764, Charles Messier discovered this new and fascinating class of objects. We see this object almost directly from its equatorial plane. If we could see the Dumbbell Nebula from one of its poles, we would probably see the shape of a ring, something very similar to what we

know as the Ring Nebula (M 57). In reasonably good weather, we can see this object well, even with low magnification.

## Telescope ABC's

What do the following terms mean?

### Focal width:

Everything that magnifies an object via an optic (lens) has a certain focal width. The focal width is the length of the path the light travels from the surface of the lens to its focal point. The focal point is also referred to as the focus. In focus, the image is clear. In the case of a telescope, the focal widths of the telescope tube and the eyepieces are combined.

### Lens:

The lens turns the light which falls on it around so that the light gives a clear image in the focal point after it has traveled a certain distance (focal width).

### Eyepiece (15):

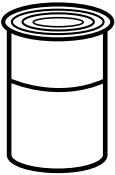

An eyepiece is a system made for your eye and comprised of one or more lenses. In an eyepiece, the clear image that is generated in the focal point of a lens is captured and magnified even more. There is a simple formula for calculating the magnification: Focal width of the telescope tube / Focal width of the eyepiece = Magnification

In a telescope, the magnification depends on both the focal width of the telescope tube and the focal width of the eyepiece.

From this formula, we see that if you use an eyepiece with a focal width of 20 mm and a telescope tube with a focal width of 600 mm, you will get the following magnification:  $600 \text{ mm} / 20 \text{ mm} = 30$  times magnification

### Erecting lens (18):



The erecting lens is set into the eyepiece holder of the telescope before the eyepiece itself. This lens can produce an additional magnification (mostly around 1.5 X) via the integrated lens in the eyepiece. The image will be turned around if you use an erecting lens, but it appears upright and even properly oriented on the vertical axis.

### Barlow Lens (18):

As an alternative to the erecting lens, a Barlow lens can also be included. The Barlow lens can be used to increase the focal width of a telescope. Depending on the type of lens, it is possible to double or even to triple the focal width.

## Magnification:

The magnification corresponds to the difference between observation with the naked eye and observation through a magnification apparatus (e.g. a telescope). In this scheme, observation with the eye is considered 'single', or 1 X magnification. Accordingly, if a telescope has a magnification of 30 X, then an object viewed through the telescope will appear 30 times larger than it would with the naked eye. See also 'Eyepiece'.

## Zenith mirror (16):

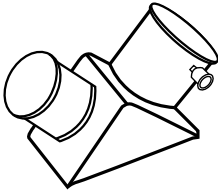

A mirror that deflects rays of light at a 90 degree angle. With a horizontal telescope tube, this device deflects the light upwards so that you can comfortably observe by looking downwards into the eyepiece. The image in a zenith mirror appears upright, but rotated around its vertical axis (what is left appears right and vice versa).

## Disposal



Dispose of the packaging materials properly, according to their type, such as paper or cardboard.

Contact your local waste-disposal service or environmental authority for information on the proper disposal.

## Warranty and Service

The regular guarantee period is 2 years and begins on the day of purchase. To benefit from an extended voluntary guarantee period as stated on the gift box, registration on our website is required.

You can consult the full guarantee terms as well as information on extending the guarantee period and details of our services at [www.bresser.de/warranty\\_terms](http://www.bresser.de/warranty_terms).